

Curved Conveyors QRC & QRS .

Due to their design characteristics, items entering the conveyor effectively rotate around the center point of the conveyor and emerge with their axis aligned to the direction of travel .

منحنى رولات QRC & QRS .

تتمتع السيور المنحنية بخاصية نقل المهينات على منحنيات ٣٠ و ٤٥ و ٦٠ و ٩٠ درجة ومضاعفاتها مع خروج المهينات ومحورها محاذ لمحور اتجاه السيور .

Factory :New Borg El Arab 2nd Zone
entrance 2c street 3 - entrance 2c street 5
Tel:+20-(03)-4624127 - 4624126 - 4624025
fax : (03) 4624291

Info@UnitelEgypt.com

Sales@UnitelEgypt.com

Cairo Office : Corniche El Nile, Maadi, Cairo
Tel +20:(0)2-25266333
Fax +20:(0)2-25264888



www.UnitelEgypt.com

f YouTube /UnitelEgypt

QRC- Curved Gravity Roller Conveyors

Features

The QRC Curved Roller Conveyors are members of the RLG family of gravity roller conveyors. They integrate seamlessly with other members of the RLG family thus offering the ability to easily change directions of conveyor lines by 90 degrees , 60, 45 and 30 degrees.

Characteristics

Due to their design characteristics, items entering the conveyor effectively rotate around the center point of the conveyor and emerge with their axis aligned to the direction of travel.

The conveyor width is a function of the length and width of the conveyed part. To select a suitable width, refer to the chart entitled “Curved Conveyors”.

Applications

QRC Conveyors allow bends in straight sections of conveyor lines.

They can be used with gravity roller conveyors or between sections of belt conveyors. In this application, motion along the curved path depends on the inertia of the conveyed item, and the slope of the conveyor



Conveyor Width Selection Chart 2

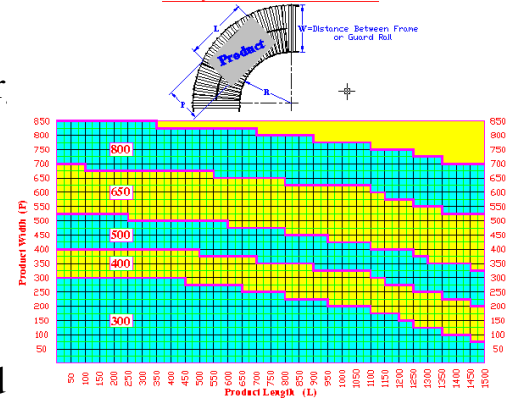

QRC- Curved Gravity Roller Conveyors

QRC Specifications

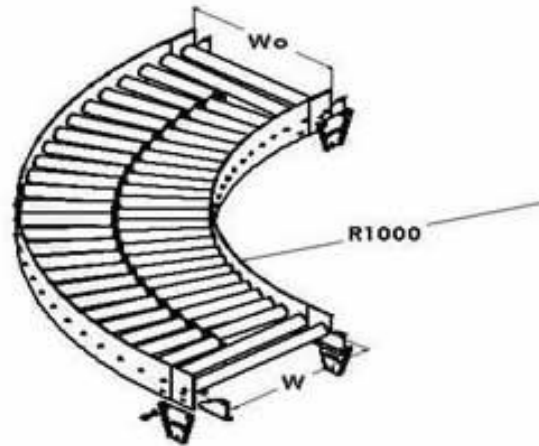

Loading Capacity	100 ~ 500 N/m
Layout Style	Interleaved
Roller Diameter	50 mm.
Roller Pitch	N/A
Linear Speed	50 m/min
Paint	Electrostatic Epoxy Powder RAL 5017 (Blue)

Dimensions

Standard Width (W) / Preferred Values

Outer Distance (W_o)

W	300	400	500	650	800
W _o	376	484	592	754	916

Standard Section Inner Diameter / Preferred Values

Inner Radius of curvature	1000
---------------------------	------

QRC- Curved Gravity Roller Conveyors

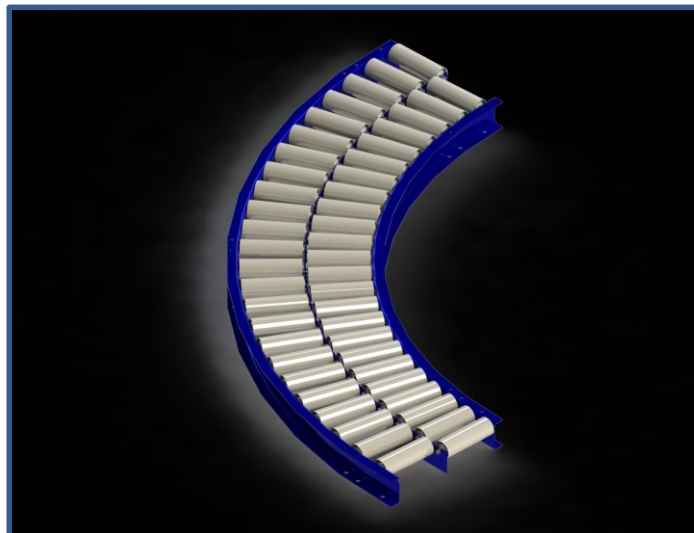

مكتب القاهرة : برج القاتوينين كورنيش المعادى
تليفون : ٢/٢٥٢٦٦٣٣٣
فاكس : ٢/٢٥٢٦٤٨٨٨

مدينة برج العرب الجديدة - المنطقة الصناعية الثانية
يونيتل/ مدخل ٢ ج شارع ٣ - مدخل ٢ ج شارع ٥
تليفون : ٣/٤٦٢٤٤٢٤-٤٦٢٤٠٢٥-٤٦٢٤١٢٦-٤٦٢٤١٢٧
فاكس : ٣/٤٦٢٤٢٩١



www.UnitelEgypt.com



/UnitelEgypt

Sales@UnitelEgypt.com

Info@UnitelEgypt.com